



# Node PON: The Bridge to Tomorrow's All-Fiber Networks

MSOs are facing new competitive pressures from Telcos. Leveraging their existing fiber networks, Telcos are targeting new markets with symmetrical gigabit broadband services. Now, MSOs are able to keep pace with the competition without costly and invasive full fiber upgrades. Aurora Networks™ Node PON technology is an economical way for MSOs to introduce symmetrical gigabit broadband services by leveraging their existing network assets. It's the ideal way to keep pace with the competition without breaking the bank.

# Unlock symmetrical gigabit speeds by leveraging your current access network assets

MSOs are facing a unique set of business challenges. Access network technologies are evolving at an unprecedented rate. In less than a decade, Distributed Access Architecture (DAA), Extended Spectrum DOCSIS® 4.0 and Full Duplex DOCSIS 4.0, virtualized CCAP platforms, and technologies to extend the downstream capacity of DOCSIS 3.1 networks have revolutionized traditional HFC network designs and operation. And—as discussions around 3 GHz DOCSIS demonstrate—this accelerated velocity of innovation shows no signs of slowing any time soon.

It seems counterintuitive to describe these innovative new technologies as challenges. But their very breadth and variety, compounded by the costs associated with their deployment, has created several questions in the industry. Which technology best suits my current and future business needs? Which offers the most “bang for the buck?” If I invest in a particular technology, how many years can I monetize my investment before I need to plan for the next generation of network upgrades? If I decide to evolve my network incrementally, what pace and cadence for new technology deployments should I adopt?

These questions are compounded by market pressures from new competitors in the broadband marketplace. Telcos, in particular, have been poaching broadband customers from MSOs at unprecedented rates by leveraging their existing fiber networks to provide symmetrical gigabit broadband services to subscribers. But it's not just about speed. Fiber's inherent low latency and better reliability aligns with a shift in consumer focus from pure speed to better overall quality of experience—a shift driven by common activities such as online gaming and video streaming in multi-device home environments. PON is also an inherently packetized network technology, fed by converged IP networks, which makes it better positioned to support the on-going transition to Over-the-Top video delivery—another way for operators to keep pace with on-going market trends.

While HFC access network technologies have solutions to some of fiber's competitive advantages—headends, for example, can be configured to support low latency DOCSIS—operators will ultimately need to replace HFC with fiber. In the short term, however, this option may not be economically or even competitively viable. A solution that enables operators to leverage their existing access network assets to adopt fiber's speed and reliability—while acting as a bridge to full fiber deployments in the future—is the best short- to mid-term option for cable operators.

Aurora Networks' Node PON platform, which enables PON and HFC or Distributed Access Architecture (DAA) coexistence from an existing node or virtual hub housing, is an economical and adaptive solution to many of these competitive and technological challenges. Node PON utilizes a Remote Optical Line Terminal (R-OLT) module, which replicates chassis-based OLT functionality, including traffic aggregation and Optical Network Terminal (ONT) management, from within the node or virtual hub. By utilizing existing node or virtual hub deployments, cable operators can use Node PON to migrate to an intermediary fiber architecture and/or supplement an existing DOCSIS HFC network with a PON overlay.

Node PON maintains DOCSIS provisioning compatibility with 10G EPON. It can also utilize XGS-PON—with Software-Defined Networking (SDN)-based Domain Management—for network provisioning and telemetry gathering. Both approaches provide a seamless, efficient path for driving fiber deeper into the network—in both suburban and rural Brownfield and Greenfield applications—while reducing the energy, maintenance, and operational requirements of traditional headend operation.

Aurora Networks provides R-OLT devices that support both leading PON technologies: IEEE EPON/10G EPON and ITU GPON/XGS-PON/MPM. For cable operators, a key strategic advantage of Aurora Networks R-OLTs is management and provisioning support using DOCSIS provisioning for either IEEE EPON/10G EPON (DPoE) or GPON/XGS-PON (DPoX). This capability requires minimal changes to current CPE and headend architectures and is fully compliant with CableLabs® DPoE v2.0 standards and CPMP technical reports. Integrating with standard DOCSIS interfaces lowers the cost of deployment with either PON technology for cable operators. For operators who have transitioned from DOCSIS provisioning for PON to an SDN-style provisioning approach, Aurora Networks has developed a cloud-based PON Domain Manager that supports platform interoperability for provisioning and ONU management, as well as zero-touch on-boarding and provisioning, to help speed new deployments. Cable operators can choose either PON technology to evolve existing Brownfield networks or expand a network via Greenfield builds.

## THE STATE OF THE MARKET

In many areas, some form of fiber infrastructure already exists; one study, in fact, estimates that approximately 70% of homes in the United States will be serviced by fiber networks by the end of 2026.<sup>1</sup> Much of this growth is the result of new entrants in the broadband market and existing Telco broadband providers expanding the number of homes passed to pursue new markets and subscribers.<sup>2</sup> This shift toward fiber-driven broadband services—and other non-traditional methods of delivering broadband services such as Fixed Wireless Access (FWA)—has created new competitive pressures in broadband markets and has led to significant churn among traditional HFC cable subscribers. The reasons for this are complex, but in general the main drivers behind subscriber churn are affordability (in the case of FWA subscriptions) and reliability.<sup>3</sup> The latter is a key advantage to PON operation, since the technology's inherent low latency can provide subscribers with better QoE than HFC networks.

While each stage of DOCSIS HFC network evolution traditionally has emphasized enhanced network speeds and extended capacities, cable operators have learned that higher speed tiers do not necessarily result in higher ARPU's.<sup>4</sup> This realization, coupled with the knowledge that PON networks generally offer better QoE, has encouraged many cable operators to rethink their traditional strategies of upgrading HFC network infrastructures to remain competitive. These new strategies, which include Node PON, place an equal emphasis on growing bandwidth, increasing speeds, and improving QoS.

One immediate effect of these competitive pressures has been a general pause in DOCSIS 4.0 deployments across the cable industry. While a handful of Tier 1 operators remain committed to DOCSIS 4.0 upgrades and rollouts, cable operators in general have adopted a more conservative approach to capital expenditures that is focused primarily on strategic upgrades to monetize their current network assets. In this fiscally conservative environment, cable operators can deploy Node PON to leverage large portions of their current network assets—including their back-office infrastructure and fielded nodes—to compete with Telco PON services at a fraction of the costs associated with DOCSIS 4.0 network rebuilds or new, centralized PON deployments.

As the state of the market suggests, now is an opportune time for cable operators to deploy Node PON technology to remain competitive with Telco PON broadband service offerings. Unlike full PON builds, Node PON enables cable operators to leverage key network assets—including back-office infrastructure and fielded nodes—to quickly and economically introduce premium broadband services to both existing and new subscribers. This ability provides a clear advantage for cable operators that need to compete with Telcos for broadband subscribers.

## THE BENEFITS OF NODE PON OPERATION

Node PON is a distributed solution. In a standard PON network architecture, a chassis-based Optical Line Terminal (OLT) is connected to a Broadband Network Gateway (BNG). The BNG is an edge router which manages subscribers by enabling only authenticated users to access the broadband network. The OLT aggregates traffic from multiple Optical Network Terminals (ONTs)—located at subscribers' premises—connected to the OLT's PON ports; in this aggregation model, the OLT distributes optical signals downstream to individual ONTs, which convert the optical signal to an electronic signal that is processed in the premises by a modem or gateway. In the upstream, the ONT converts electronic signals received from a modem or gateway in the premises to optical signals, which are then routed to the OLT for distribution upstream back to the BNG. Chassis-based OLTs can be deployed in either the headend or the field, depending on the network design.

R-OLT modules perform these same functions from within a node or virtual hub housing. This capability enables cable operators to extend fiber signals to the edge of the network without the costs associated with chassis-based OLT deployments, such as new underground feeder installations and centralized splitter deployments (which also require additional fiber runs). Moreover, this modular approach can help cable operators speed time to market for PON-based broadband services. Market analysis has shown a general slowdown in fiber expansion and overbuild projects among Telcos in 2025, due largely to rising labor costs, inflation, and

<sup>1</sup> Michael Emmendorfer, "Beyond 10G PON Technologies and Network Slicing: 50G PON Capacity + PON Slicing are Game Changers" (Presented and published at SCTE TechExpo24), 4.

<sup>2</sup> Tom Whitaker, "Telecom in Review (2025): How FTTH and BEAD are Shaping the Broadband Landscape." <https://tinyurl.com/ynj2428a>. Accessed 3-6-26.

<sup>3</sup> Chris Mooney, Naveen Sarma, and Willima Savage, "Industry Credit Outlook: U.S. Cable Industry Bundles Up For Subscriber Losses." <https://tinyurl.com/5b85cz9r>. Accessed 2-18-26.

<sup>4</sup> Marko Estacio and Brian Lane, "A Pragmatic Approach to Deploying Broadband in LATAM with Standards-Based PON Technologies" (Presented and published at SCTE TechExpo23), Figure 2, 5.

tariffs.<sup>5</sup> Due to these factors, timelines for new fiber deployments are expected to lengthen 2026.<sup>6</sup> Cable operators can quickly and economically deploy Node PON technology to take advantage of these extended, new fiber deployment timelines, thereby gaining a much-needed competitive advantage in areas that would support PON-based broadband services.

Identifying these areas is extremely important, since Node PON deployments typically support only a fraction of the densities available with chassis-based ONT. Aurora Networks R-OLT modules feature four PON ports, each of which supports a maximum of 128 subscribers per port, or 512 subscribers per module, using a 1:64 split ratio. Aurora Networks VHub housings support a maximum of three R-OLT modules, or 1,500 subscribers, while node housings support a maximum of two R-OLT modules, or 1,000 subscribers; generally, these densities are not economically viable in heavily populated suburban or urban areas, which are better served by high-density, chassis-based OLTs. As a rule of thumb, then, Node PON provides excellent return on investment in lower density rural or suburban areas in which the subscriber bases are long distances from fixed headend or hub facilities. After an area of the network exceeds 1,500 subscribers, however, a standard PON architecture using a chassis-based OLT may usually—but not always—be a better solution than an R-OLT deployment.

### Operational Benefits of Node PON

Node PON deployments provide benefits throughout the network, from back-office provisioning to performance in the home. Some of the more notable benefits include:

- **Lower PON Port Utilization:** Node PON operation supports lower split ratios than chassis-based OLTs because of the lower densities per PON port. In typical Node PON operating scenarios, this lower density is a benefit; lower split ratios enable more efficient bandwidth distribution to subscribers and provides better economies of scale for future growth from the initial Node PON deployment.
- **Standards-based, disaggregated management:** this capability enables economy of scale driven by virtual device management and provisioning and proactive, automated triage and troubleshooting in the network.

Aurora Networks offers multiple options for automated, intelligent virtual PON management that facilitate the allocation and distribution of high-bandwidth, PON-based broadband services. These solutions include **vBNG Evo™**—a virtualized Broadband Network Gateway that seamlessly integrates with Node PON technology—and **PON Evo™ SDN**, which enable cable operators to speed deployments and easily scale their networks as they add subscribers. Additionally, these solutions support zero-touch provisioning of R-OLTs and ONUs. Since these management solutions are cloud-based, they can also significantly reduce OPEX associated with physical BNGs and other headend-based management solutions.

- **Support for XGS-PON:** XGS-PON supports symmetrical speeds of 10 Gbps, a significant increase over previous generation EPON and GPON technologies. These symmetrical speeds greatly increase upstream capacity beyond what is generally available in HFC networks.
- **Multi-vendor Interoperability:** Node PON technology supports DOCSIS Provisioning of EPON (DPoE™) and DOCSIS Provisioning of PON (DPoX, applicable to GPON, XGS-PON, and 50G PON networks), which enables the provisioning of PON equipment using existing back-office architectures and DOCSIS provisioning systems. Additionally, DPoX and DPoE enables equipment from multiple vendors to seamlessly integrate with an Aurora Networks Node PON deployment. Thus, Node PON deployments can leverage existing equipment, platforms, and powering resources to mitigate some of the costs associated with full PON builds.
- **Enhanced network reliability:** low latency is “baked in” to fiber optic transmission, due to the elimination of HFC actives in the outside plant. Home networks serviced by PON are therefore more reliable, and provide better QoE for subscribers, than those serviced by HFC. Additionally, PON’s inherent low latency provides superior support for current large-scale applications such as wireless backhaul.<sup>7</sup>

<sup>5</sup> Fiber Broadband and Cartesion. *Fiber Deployment Cost Annual Report 2025*, 13..

<sup>6</sup> *Ibid.*, 30..

<sup>7</sup> Ben Ragel and Reema Ahmed, “Boosting FTTH Network Performance: Key Strategies” (Presented and published at SCTE TechExpo 24), 5–6.

Node PON operation also enhances network reliability by providing higher quality signals to the home. An HFC network's reliance on electronic actives can lead to Modulation Error Ratio (MER), Signal to Noise Ratio (SNR), and ingress/egress noise, all of which can potentially degrade signals and interfere with home network performance. These issues are typically eliminated in PON networks.

- More efficient bandwidth allocation: according to the 20/80 rule, 20% of broadband subscribers account for 80% of bandwidth use.<sup>8</sup> Node PON deployments enable cable operators to market premium PON-based broadband services to these high-capacity consumers while continuing to use legacy HFC networks to service remaining subscribers. By off-loading these heavy users onto a new Node PON overbuild, cable operators can more efficiently allocate bandwidth to enhance QoS and improve QoE for all their subscribers.

## Node PON Deployment Scenario: Overlaying Node PON in a Legacy RFoG Architecture

With competitive pressures from Telco broadband service offerings increasing, many cable operators may be wondering if it makes sense to leverage their existing RF over Glass (RFoG) architectures to maintain a competitive advantage. RFoG was introduced to the cable market as an intermediary form of PON, a solution that operated with passives in the field while comfortably coexisting with established HFC networks. At first glance, this approach may seem to have continuing viability in today's competitive marketplace. But a closer look reveals potential problem areas that aren't applicable to Node PON operation.

While legacy RFoG architectures share some advantages with Node PON—for example, RFoG, like Node PON, can leverage fielded CPE and back-office architectures to deliver voice, video, and Internet services—they do not support either current or next-generation PON technologies such as XGS-PON. As a result, RFoG architectures have significant operational limitations that are not applicable to current and next-generation Node PON technology.

These limitations include:

- Optical Beat Interference (OBI): OBI is a common problem in RFoG networks. OBI occurs in upstream traffic when two or more RFoG Optical Network Unit (R-ONU) transmitters with the same or very similar optical wavelengths transmit to the same headend receiver at the same time. When OBI occurs, a full spectrum flat level noise signal is generated across the entire return bandwidth at the receiver's output, impacting transmission at the CMTS input port. All cable modems connected to that port are affected, which severely impacts operation in the subscribers' home network. RFoG operation therefore requires operators to eliminate OBI with either tunable R-ONUs, which prevent upstream wavelengths from overlapping, or multi-diode receivers, which assign a dedicated upstream wavelength to each R-ONU, in place of standard optical splitters.

Node PON networks, on the other hand, use Time Division Multiple Access (TDMA) in the upstream, which enables the Optical Network Unit (ONU) to transmit at any given time and eliminates the signal congestion that leads to OBI. This capability eliminates the need for specialized network equipment such as tunable R-ONUs and supports better network performance and QoE for subscribers.

- Asymmetrical speeds: unlike Node PON, RFoG networks have limited upstream capacity. RFoG networks typically leverage GPON technology, which supports asymmetrical speeds of ~2.5 Gbps in the downstream and ~1.25 Gbps in the upstream—approximately the same speeds currently available in standard, high-split DOCSIS 3.1 networks. These speeds are significantly lower than the symmetrical ~10 Gbps speeds supported by current XGS-PON technology and well below the symmetrical 50 Gbps and 100 Gbps speeds supported by next-generation PON technologies.
- Operational limitations: Node PON supports significantly greater optical budgets than RFoG architectures. This capability, in turn, supports extended network reach of up to 80 km—almost double the reach of a typical RFoG network—which greatly increases the potential number of homes passed supported by Node PON networks in low-density rural areas.
- Flexible scalability: RFoG operates from a fixed network architecture, which requires comprehensive upgrades to support expanded capacities and speeds. Node PON's modular design and cloud-based headend and management platforms, on the

<sup>8</sup> Estacio and Lane, 7.

other hand, enable cable operators to quickly and easily scale for a variety of upgrade scenarios, including expanded bandwidths, new service groups, and Greenfield PON deployments that leverage existing HFC architectures.

Cable operators can mitigate these operational disadvantages by installing R-OLT modules in fielded virtual hubs for Node PON operation, which enhances current network operation while providing a bridge to full PON networks in the future. These deployments leverage Node PON's operating advantages to provide a foundation from which cable operators can quickly and economically enter new markets, such as small and medium businesses, and deploy new premium symmetrical services like 50G PON and Wi-Fi® backhaul. In the meantime, the legacy RFoG portion of the network can continue to service areas with lower bandwidth consumption and traffic that do not require premium symmetrical services.

Figure 1 shows an example of an existing RFoG architecture overlaid with Node PON.

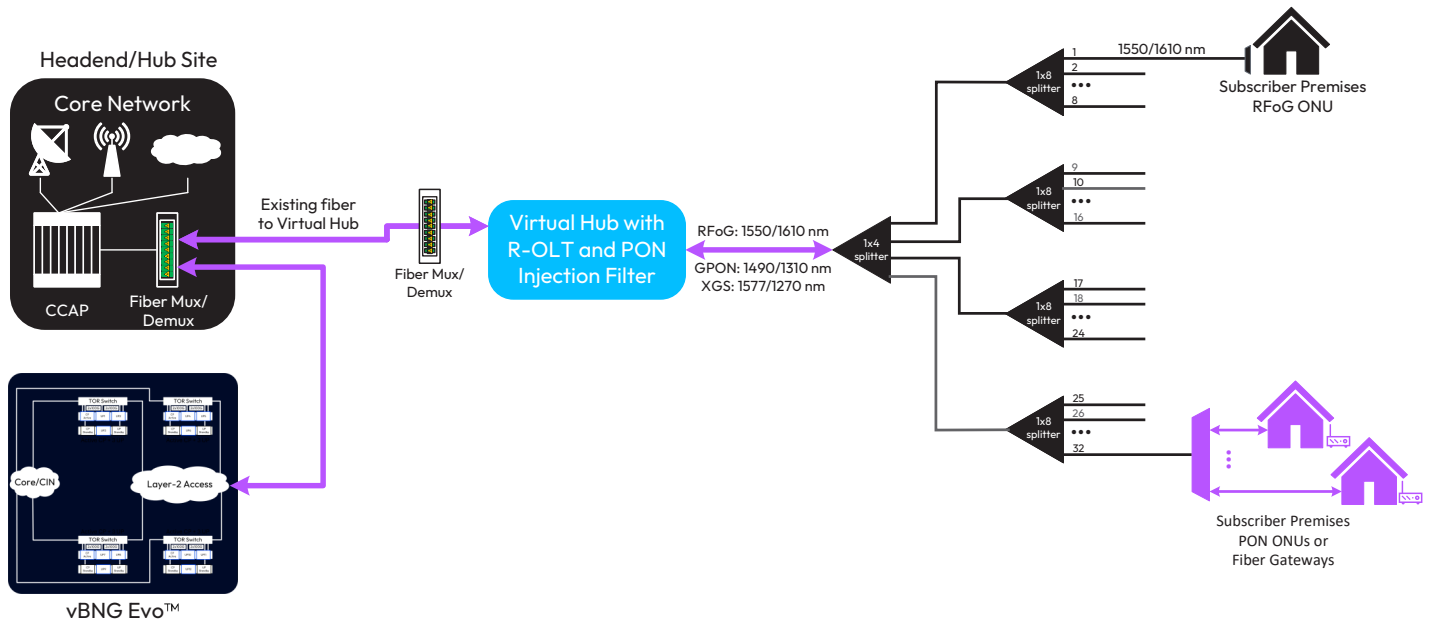

Figure 1. RFoG network overlaid with Node PON

## Node PON Deployment Scenario: Hybrid PON/HFC

A Node PON network can coexist with a cable operator's existing HFC network architecture in both Greenfield and Brownfield deployments. In this network design, traditional HFC receivers and transmitters and R-OLT modules are installed in, and operate from, a single node housing. This enables electronic signal distribution to HFC-based service groups and optical signal distribution to PON-based service groups from different ports on the node. Hybrid PON/HFC nodes support up to 2x2 segmentation for HFC operation.

In either Greenfield or Brownfield deployment scenarios, Node PON enables cable operators to monetize their existing actives, fiber runs, and powering resources while, at the same time, extending the life of these current network assets for the foreseeable future. If cable operators plan to eventually transition to full PON operation at a later date, Node PON is an economical first step toward that goal: a “pay as you grow” solution, Node PON mitigates the need for large, up-front CAPEX investments while fully supporting symmetrical PON-based broadband services.

Figure 2 shows HFC optical modules and an R-OLT module installed in an Aurora Networks NC4000® node housing.

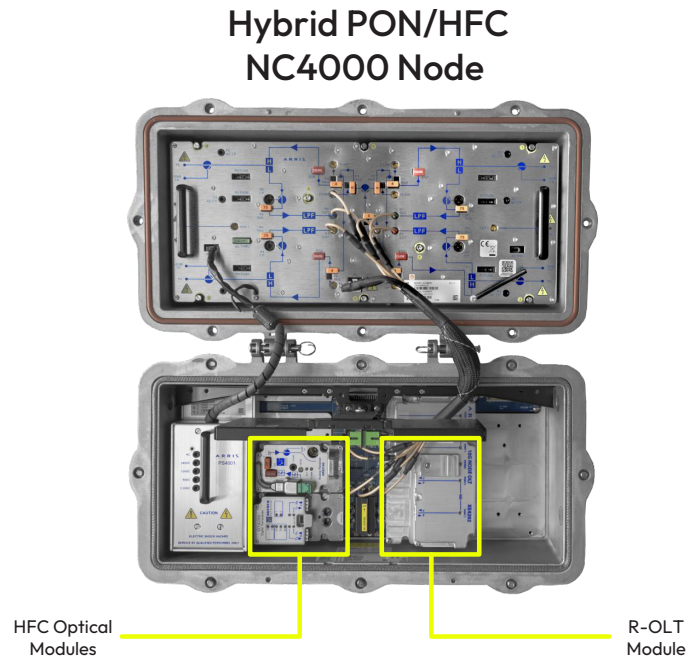

Figure 2. Hybrid PON/HFC Node

## Greenfield Deployments

Cable operators can leverage Node PON to service Greenfield deployments using their existing HFC network architecture. In this scenario, Node PON expands network coverage into a Greenfield area that is adjacent to the primary HFC network; the PON portion of the hybrid network is analogous to a tributary that branches off from the main “stream” or pipe of electronic HFC signals, feeding optical signals to new service groups. This deployment strategy enables cable operators to expand network coverage and deploy PON-based broadband services to areas not previously serviced by their existing HFC network. It can also be used to extend the reach of the network. Greenfield Hybrid PON/HFC deployments are an ideal solution for capturing new business in lower density rural or suburban areas or recapturing Telco subscribers whose homes were previously serviced by lower network bandwidths and speeds.

Figure 3 shows an example of a Hybrid PON/HFC Greenfield architecture.

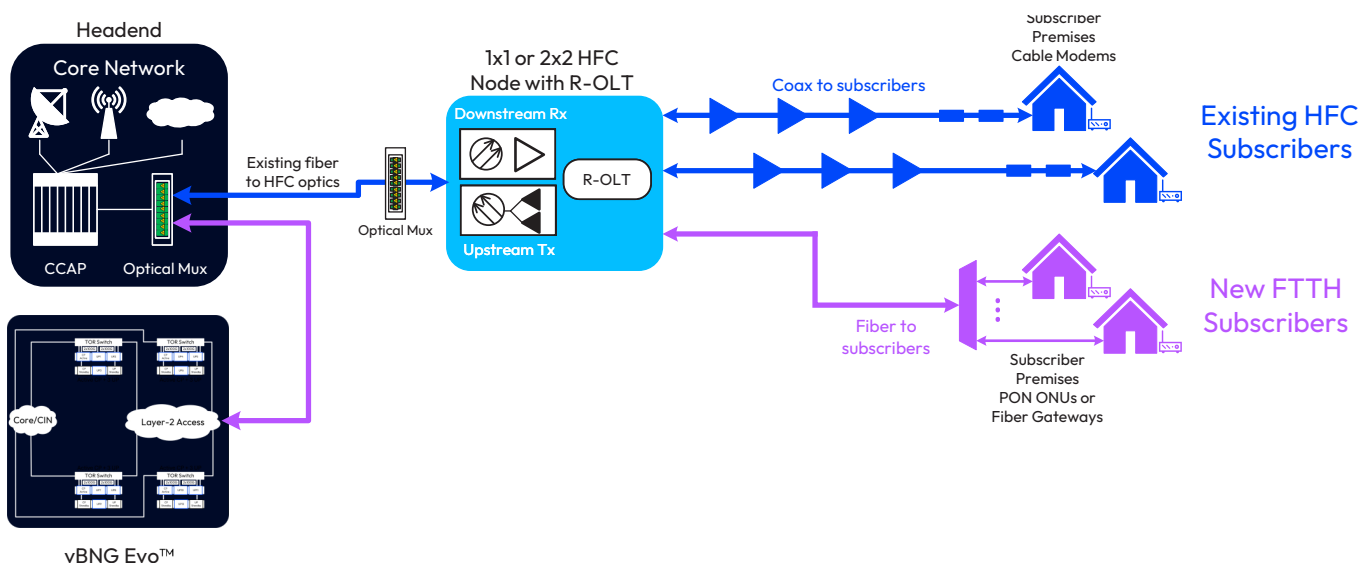

Figure 3. Hybrid PON/HFC Greenfield architecture diagram

## Brownfield Deployments

Hybrid HFC/PON Brownfield deployments can be used to add significant capacity to existing access networks by using existing fiber runs, channelized optics, and existing node enclosures to support Node PON operation. The main capacity boost, as noted earlier in this Solution Brief, is a quantum leap in upstream capacity. Upstream capacity has been limited in traditional HFC network designs—even in current iterations of DOCSIS—because upstream bandwidths occupy a significantly smaller portion of the spectrum than downstream bandwidths in RF operation. XGS-PON's support for symmetrical 10G operation, on the other hand, enables cable operators to scale both the upstream and the downstream to support current services and anticipate future services, such as virtual reality and 8K video, that may require more upstream bandwidth.

This symmetric 10G capability enables cable operators to strategically deploy Node PON in existing areas of their Brownfield networks that either have clusters of subscribers that consume higher than usual amounts of bandwidth (refer to the discussion of the 20/80 rule above) or, perhaps more pointedly, are bleeding subscribers due to competitive pressures from Telcos. In either case, Node PON can help cable operators reduce subscriber churn, retain current subscribers, and recapture subscribers that switched to Telco broadband services.

Figure 4 shows an example of a Hybrid HFC/PON Brownfield architecture.

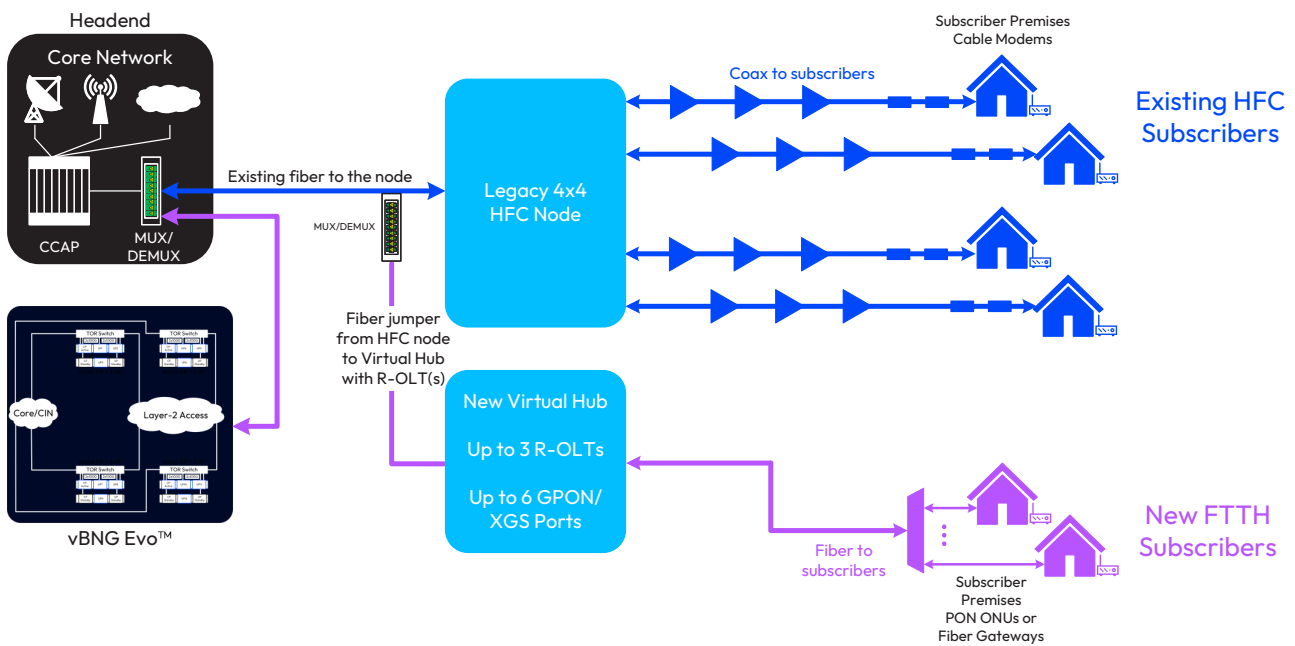
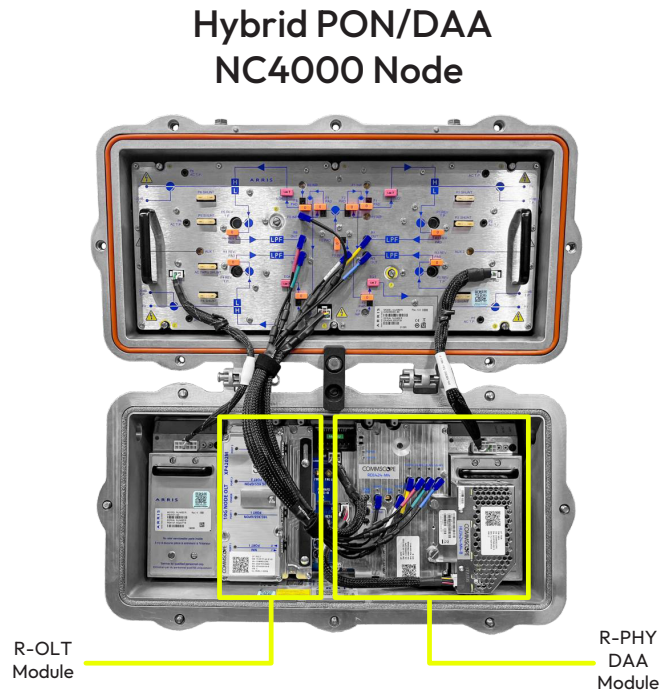

Figure 4. Hybrid PON/HFC Brownfield architecture diagram

## Node PON Deployment Scenario: Hybrid PON/DAA

Many cable operators have transitioned their access networks from HFC to DAA operation; other cable operators are planning to do so soon. DAA enables cable operators to push headend functionality deeper into the network and closer to the end user by installing Remote PHY (R-PHY) or Remote MACPHY (R-MACPHY) modules into fielded nodes. This modular approach also enables DAA and R-OLT modules to coexist in the same housing, enabling hybrid DAA/PON operation from a single node.

Figure 5 shows DAA R-PHY and Node PON R-OLT modules installed in an Aurora Networks NC4000 node housing.



DAA and Node PON share the same ability to completely virtualize headend operation; optimal DAA performance requires a virtual CCAP platform, such as Aurora Networks' vCCAP Evo™, to support evolving densities, throughput, and efficiency requirements—which is analogous to Node PON's ability to leverage the vBNG Evo and PON Evo SDN platforms to optimize R-OLT operation. Additionally, operators can leverage Node PON's DPoX capabilities to provision new PON equipment using existing back-office architectures and DOCSIS provisioning systems, including PON equipment from multiple vendors. This dual, virtualized headend architecture has several operating benefits beyond the speed, capacity, and inherent reliability of DAA and PON, including superior economies of scale (up or down, as needed); disaggregated, software-based design that supports more and varied features than chassis-based cores; significant OPEX savings; and variety of proactive, AI-driven remote management capabilities.

A dual DAA/Node PON network architecture has the same design principles and benefits discussed in [“Node PON Deployment Scenario: Hybrid PON/HFC” on page 5](#), including the ability to branch PON services from the primary DAA network for Greenfield deployments and expand capacity in Brownfield deployments.

Figure 6 shows an example of a Hybrid PON/DAA network architecture.

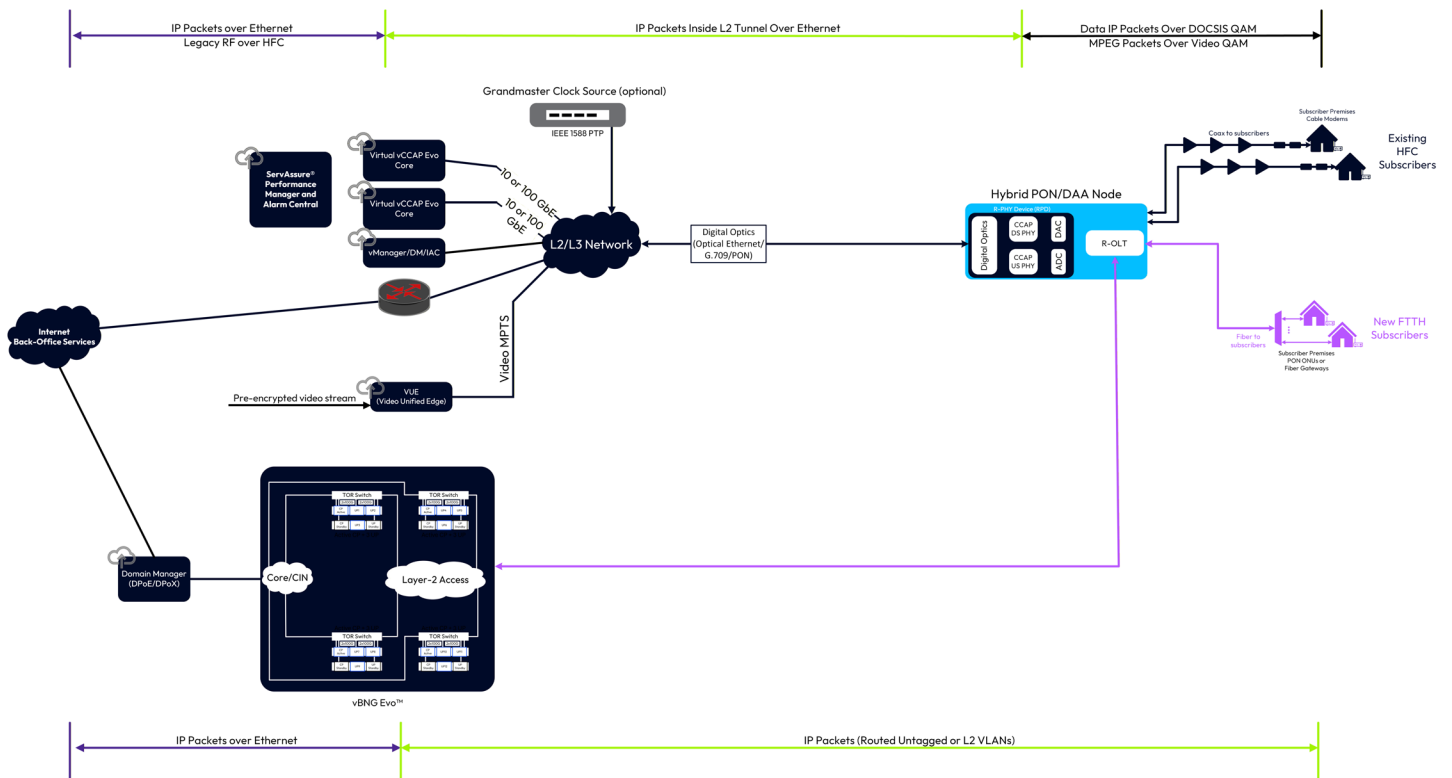

Figure 6. Hybrid PON/HFC Brownfield architecture diagram

## The Bridge to Tomorrow: Node PON and Aurora Networks

Node PON is a cost-effective way to extend the life of legacy RfOG and HFC access networks. It can also coexist with new DAA access network upgrades or deployments. Cable operators can deploy Node PON in their current networks to introduce premium, symmetrical PON-based broadband services to existing subscribers and also leverage Node PON deployments to pursue new subscribers from markets not traditionally serviced by HFC cable networks. Node PON is the perfect bridge between today's HFC access networks and tomorrow's all-fiber infrastructures.

Aurora Networks has a full portfolio of end-to-end solutions that support a variety of Node PON deployment scenarios. Cable operators can deploy these solutions to maintain a competitive advantage with Telco PON offerings at a fraction of the cost associated with centralized PON deployments. Contact your Aurora Networks sales representative to find out how Node PON can enhance the performance of your current access network and help you capture new subscribers while retaining your current ones.

When service providers want innovative, cutting-edge access network solutions to maintain a competitive advantage in today's challenging broadband marketplace, they turn to Aurora Networks. Aurora Networks' end-to-end solutions feature the latest access network technologies while providing a clear path toward tomorrow's symmetrical gigabit deployments. With decades of expertise in developing broadband technologies, Aurora Networks is the ideal partner for service providers planning to enhance, optimize, and refresh their current access network assets. Discover more at [vistancenetworks.com](http://vistancenetworks.com).



---

[vistancenetworks.com](http://vistancenetworks.com)

Visit our website or contact your local CommScope representative for more information.

© 2026 Vistance Networks, Inc. All rights reserved.

Aurora Networks and its associated logos are trademarks of Vistance Networks, Inc. and/or its affiliates in the U.S. and other countries. DOCSIS is a registered trademark of Cable Television Laboratories, Inc. Wi-Fi is a registered trademark of the Wi-Fi Alliance. For additional trademark information see [www.vistancenetworks.com/trademarks/](http://www.vistancenetworks.com/trademarks/). All product names, trademarks and registered trademarks are property of their respective owners..

ANS-MKTG-SB-002-26 (03/26)\_RevA